

EGS002 Sinusoid Inverter Driver Board User Manual

1. Description

EGS002 is a driver board specific for single phase sinusoid inverter. It uses ASIC EG8010 as control chip and IR2110S as driver chip. The driver board integrates functions of voltage, current and temperature protection, LED warning indication and fan control. Jumper configures 50/60Hz AC output, soft start mode and dead time. EGS002 is an improved version of EGS001 that is compatible of EGS001's original interfaces. EGS002 also integrates cross-conduction prevention logic to enhance its ability of anti-interference, and LCD display interface for users' convenience to use chip's built-in display function.

EG8010 is a digital pure sine wave inverter ASIC (Application Specific Integrated Circuit) with complete function of built-in dead time control. It applies to DC-DC-AC two stage power converter system or DC-AC single stage low power frequency transformer system for boosting. EG8010 can achieve 50/60Hz pure sine wave with high accuracy, low harmonic and distortion by external 12MHz crystal oscillator. EG8010 is a CMOS IC that integrates SPWM sinusoid generator, dead time control circuit, range divider, soft start circuit, circuit protection, RS232 serial communication, 12832 serial LCD unit, and etc.

2. Circuit Schematic

EGS002 Driver Board Schematic

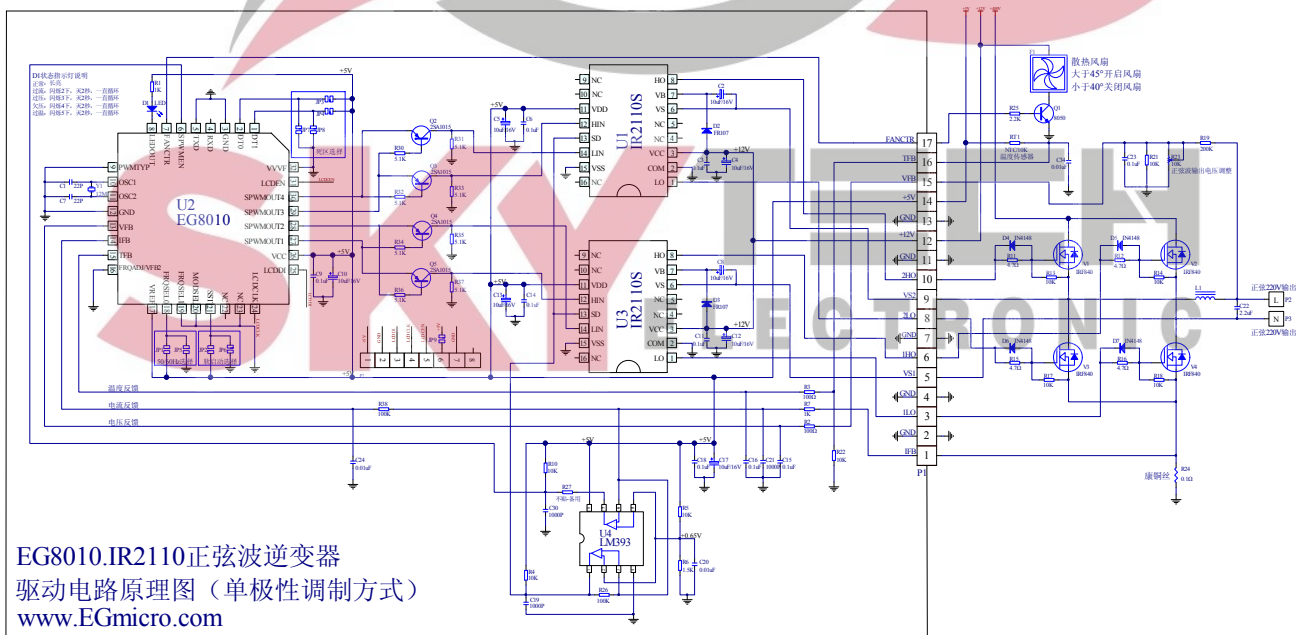

Figure 2-1. EGS002 Sinusoid Inverter Driver Board Schematic

3. Pins and jumpers

3.1 EGS002 Front View

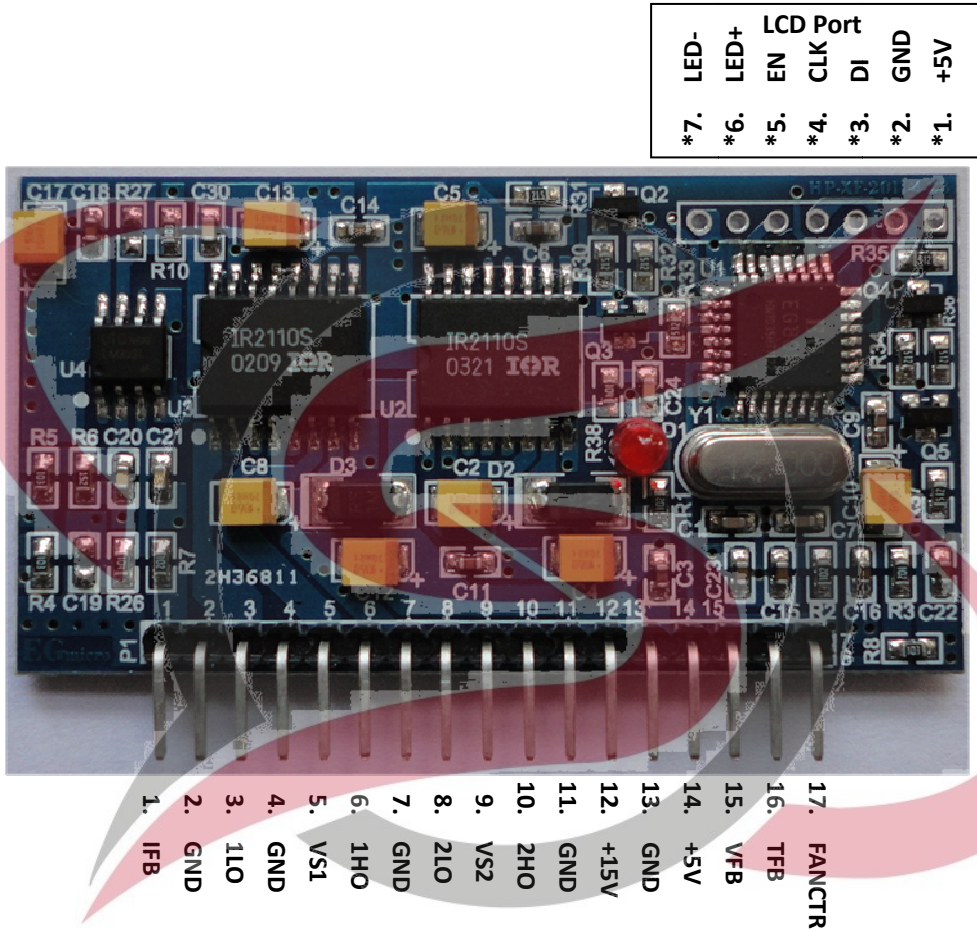

Figure 3-1. EGS002 Driver Board Pin Definition

3.2 Pin Description

Designator	Name	I/O	Descriptions
1	IFB	I	AC Output Current Feedback. Overcurrent protection turns on when pin's input voltage is over 0.5V
2	GND	GND	Ground
3	1LO	O	Right bridge low sidegate drive output
4	GND	GND	Ground
5	VS1	O	Right bridge high side floating supply return
6	1HO	O	Right bridge high side gate drive output
7	GND	GND	Ground
8	2LO	O	Left bridge low side gate drive output
9	VS2	O	Left bridge high side floating supply return
10	2HO	O	Left bridge high side gate drive output

11	GND	GND	Ground
12	+12V	+12V	+12V voltage input. (range: 10V-15V)
13	GND	GND	Ground
14	+5V	+5V	+5V power supply
15	VFB	I	AC Output voltage feedback. Referring to EG8010 datasheet for specific function and circuit.
16	TFB	I	Temperature feedback. Overtemperature protection turns on when pin's input voltage is over 4.3V
17	FANCTR	O	Connect to the fan control. When detects a temperature over 45°C, FANCTR outputs high level "1" to turn on the fan. When the temperature is lower than 40°C, FANCTR outputs low level "0" to turn off the fan.
* The followings are LCD display interface			
*1	+5V	+5V	+5V power supply for the LCD
*2	GND	GND	Ground
*3	LCDDI	I/O	LCD Serial Data
*4	LCDCLK	O	LCD Serial Clock
*5	LCDEN	O	LCD Chip Select
*6	LED+	+5V	+5V power supply for the backlight
*7	LED-	GND	Ground

3.3 Jumper settings

Designator	Name	Mark	Setting Description
1	FS0	JP1	When JP1 is short, it selects AC output frequency at 60Hz
		JP5	When JP5 is short, it selects AC output frequency at 50Hz
2	SST	JP2	When JP2 is short, it enables 3 seconds soft start mode
		JP6	When JP6 is short, it disables soft start mode
3	DT0	JP3	When JP7 and JP8 are short, dead time is 300ns.
		JP7	When JP3 and JP8 are short, dead time is 500ns.
4	DT1	JP4	When JP4 and JP7 are short, dead time is 1.0us.
		JP8	When JP3 and JP4 are short, dead time is 1.5us.
*5	LED+	JP9	When JP9 is short, LCD backlight is on When JP9 is open, LCD backlight is off

The driver board's jumper JP5, JP2, JP7 and JP8 are shorted as default setting, corresponding to 50Hz output, soft start mode on, 300nS dead time. Users can change these based on their needs.

Warning: Jumper of the same function CANNOT be short circuited at the same time. (For example: JP1 And JP5 cannot be short at the same time.)

3.4 LED Warning Indication

EGS002 driver board provides LED warning indication function. User can determine problem according to the followings:

- Normal: Lighting always on
- Overcurrent: Blink twice, off for 2 seconds, and keep cycling
- Overvoltage: Blink 3 times, off for 2 seconds, and keep cycling
- Undervoltage: Blink 4 times, off for 2 seconds, and keep cycling
- Overtemperature: Blink 5 times, off for 2 seconds, and keep cycling

3.5 LCD Display Interface

EGS002 integrates LCD display interface for users' convenience to test chip's built-in display function that EG8010 supports. Shielding cable is required for connecting EGS002 driver board and LCD, otherwise inverter's high voltage and high current environment will significantly interfere driver board's operation.

EG8010 supports 12832 LCD (default) or LCD3220 that we specifically designed. Because two LCDs' drivers are different, user has to specify if intends to buy LCD3220. Salesperson will ship 12832 LCD as default if not otherwise specified.

- **12832 LCD Connection Diagram:**

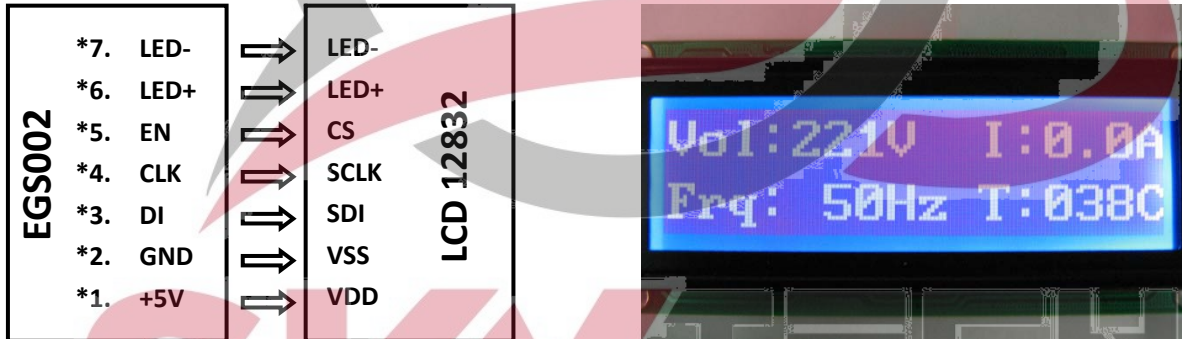

Figure 3-2. Connection between EGS002 and 12832 LCD Figure 3-3. 12832 LCD Display



Note:

There are many modules of LCD in the market. EG8010 supports majority of 12832 LCD based on control IC ST7920. Different LCDs may vary a little in pin map, name or description; user can obtain information online.

- **LCD3220 Connection Diagram:**

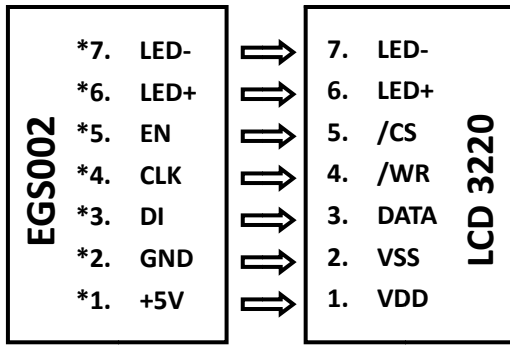

Figure 3-4. Connection between EGS002 and LCD3220

Figure 3-5. LCD3220 Display

4. Testing

EGS002 Driver Board Testing

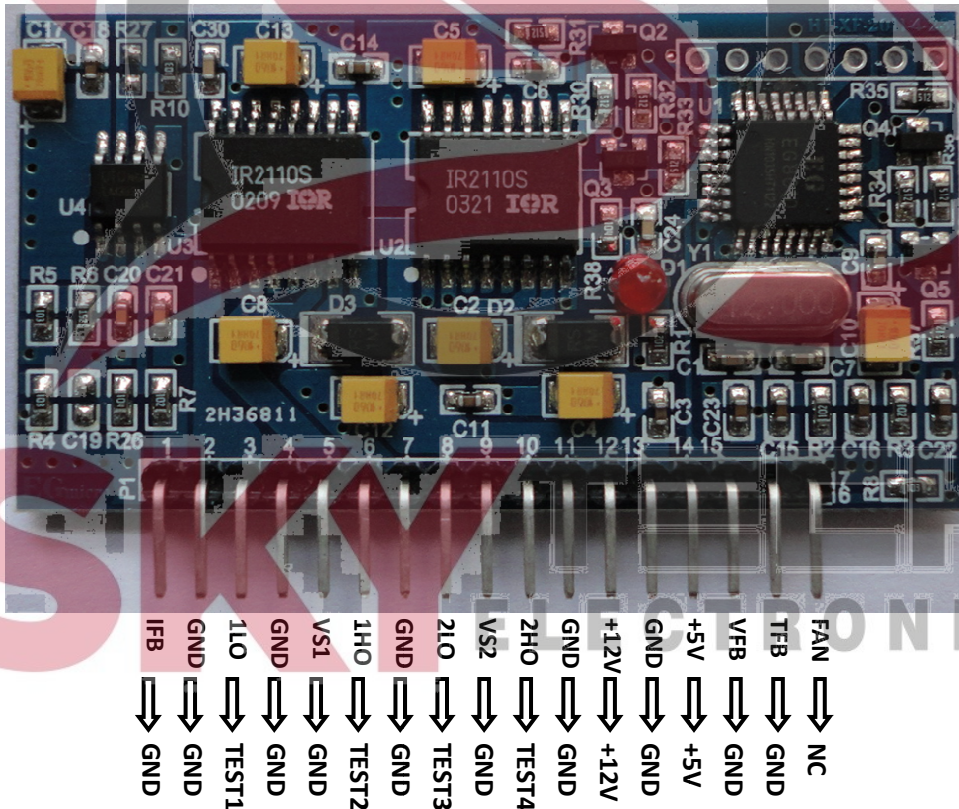

Figure 4-1. EGS002 Driver Board Connection Diagram

EGS002 Driver Board Testing

- 1) Connect IFB, VS1, VS2, VFB and TFB to the ground during testing.
- 2) Connect DC 5V to pin +5V and DC 12V (voltage can be between 12V and 15V) to pin +12V
- 3) Connect oscilloscope to TEST1 to TEST4 to observe waveforms. TEST1 and TEST2 outputs

fundamental frequency square wave, which is shown as CH1 blue waveform in figure 5-3. TEST3 and TEST4 outputs unipolar modulation wave. When TEST3 and TEST4 are connected to RC filter, it will output waveform shown as CH2 red waveform in figure 5-3.

- 4) Because pin VFB is grounded, undervoltage protection is going to turn on in 3 seconds. Test1~Test 4 will all shut down; LED blinks four times, off for 2 seconds and keep cycling. When EGS002 is connected to the power supply again, user can observe waveforms for another 3 seconds.

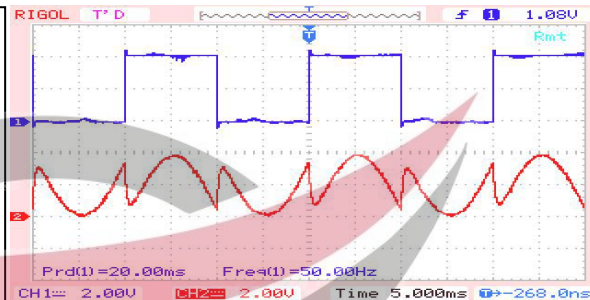
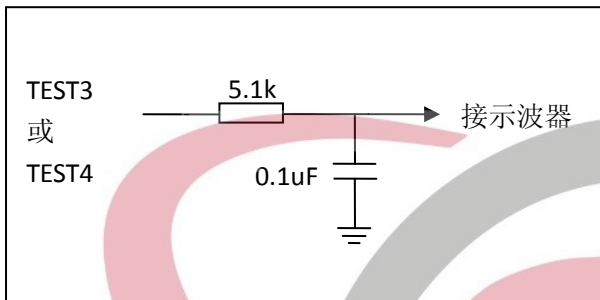

Figure 4-2. EGS002 SPWM RC filter circuit

Figure 4-3. Output waveform of TEST 2 and TEST3

5. Dimension Diagram

EGS002 Dimension Diagram



图 5-1. EGS002 Driver board dimension diagram

㊦ 限定参数

Item	Symbol	Standard Value	Unit
Supply Voltage	VDD	-0.3~+5.5	V
Input Voltage	VIN	VSS-0.3~VDD+0.3	V
Operating Temperature	Top	0~+50	℃
Storage Temperature	Tstg	-10~+60	℃

*Note: Stresses above those listed under "Absolute Maximum Ratings" may cause permanent damage to the device. These are stress ratings only. Functional operation of this device at these or any other conditions above those indicated in the operational sections of this specification is **not implied** and exposure to absolute maximum rating conditions for extended periods may affect device reliability.

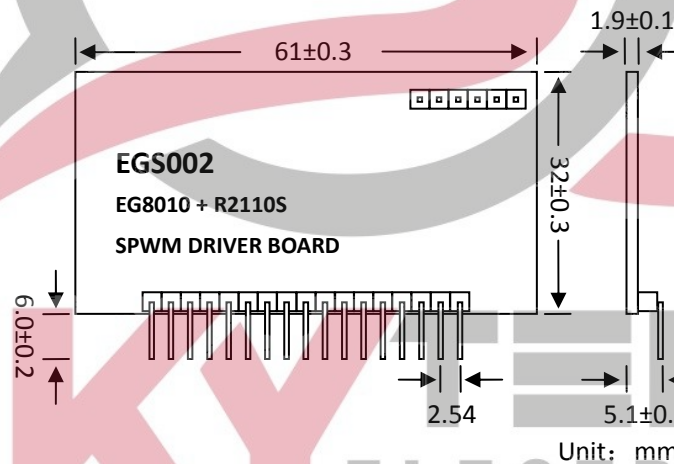
㊦ 直流特性(D.C.Characteristics)

Parameter	Symbol	Min	Type	Max	Unit	Test Condition	
						VDD	Condition
Operating Voltage	VDD	2.4	-	5.2	V	-	-
Operating Current	IDD	-	150	300	μA	3V	No load
		-	300	600	μA	5V	On-chip RC oscillator
Operating Current	IDD	-	60	120	μA	3V	No load
		-	120	240	μA	5V	Crystal oscillator
Operating Current	IDD	-	100	200	μA	3V	No load
		-	200	400	μA	5V	External clock source
Standby Current	ISTE	-	0.1	5	μA	3V	No load
		-	0.3	10	μA	5V	Power down mode
Input Low Voltage	VIL	0	-	0.6	V	3V	DATA,/WR,/CS,/RD
		0	-	1.0	V	5V	
Input High Voltage	VIH	2.4	-	3.0	V	3V	DATA,/WR,/CS,/RD
		4.0	-	5.0	V	5V	
DATA,BZ,/BZ,/IRQ	IOL1	0.5	1.2	-	mA	3V	VOL=0.3V
		1.3	2.6	-	mA	5V	VOL=0.5V
DATA,BZ,/BZ	IOH1	-0.4	-0.8	-	mA	3V	VOH=2.7V
		-0.9	-1.8	-	mA	5V	VOH=4.5V
LCD Common Sink Current	IOL2	80	150	-	μA	3V	VOL=0.3V
		150	250	-	μA	5V	VOL=0.5V
LCD Common Source Current	IOH2	-80	-120	-	μA	3V	VOH=2.7V
		-120	-200	-	μA	5V	VOH=4.5V
	IOL3	60	120	-	μA	3V	VOL=0.3V

AC Characteristics (A.C.Characteristics)

Symbol	Parameter	Test Condition		Min	Typ	Max	Unit
		VDD	Conditions				
fSYS1	System Clock	3V	On-chip RC oscillator	-	256	-	kHZ
		5V		-	256	-	kHZ
fSYS2	System Clock	3V	Crystal oscillator	-	32.768	-	kHZ
		5V		-	32.768	-	kHZ
fSYS3	System Clock	3V	External clock source	-	256	-	kHZ
		5V		-	256	-	kHZ
fLCD	LCD Clock	-	On-chip RC oscillator	-	fSYS1/1024	-	HZ
		-	Crystal oscillator	-	fSYS2/128	-	HZ
		-	External clock source	-	fSYS3/1024	-	HZ
tcoM	LCD Common Period	-	n: Number of COM	-	n/fLCD	-	s
fclk1	Serial Data Clock(/WR Pin)	3V	Duty cycle 50%	-	-	150	kHZ
		5V		-	-	300	kHZ
fclk2	Serial Data Clock(/RD Pin)	3V	Duty cycle 50%	-	-	75	kHZ
		5V		-	-	150	kHZ
ftone	Tone Frequency	-	On-chip RC oscillator	-	2.0 or 4.0	-	kHZ
tw	Pulse Width Serial Data Clock	3V	Write mode	3.34	-	-	µs
			Read mode	6.67			
		5V	Write mode	1.67			
			Read mode	3.34			
tcs	Serial Interface Reset Pulse Width	-	/CS	-	250	-	ns
trtf	Rise/Fall Time Serial Data Clock	3V	-	-	120	-	ns
		5V	-	-	120	-	ns
tsu	Setup Time DATA to Serial Data Clock	3V	-	-	120	-	ns
		5V	-	-	120	-	ns
th	Hold Time DATA to Serial Data Clock	3V	-	-	120	-	ns
		5V	-	-	120	-	ns
tn	Low to /cs High Serial Data Clock	3V	-	-	100	-	ns
		5V	-	-	100	-	ns
trec	/cs High to Serial Data Clock High	3V	-	-	100	-	ns
		5V	-	-	100	-	ns
tw	Serial Interface Reset High	3V	-	-	250	-	ns
		5V	-	-	250	-	
tsu	/cs Low to Serial Pulse width Serial Data Clock High	3V	-	-	100	-	ns
		5V	-	-	100	-	